



# H45-H180 s Hydraulic Hammers



Hammer models	H45 through H180 s
Working weight	286 - 8,360 lb (130 - 3800 kg)
Energy class	200 - 11,000 ft-lb (271 - 14,913 J)
Carrier weight	2,860 - 176,000 lb (1.3 - 80 t)

# Hydraulic Hammers H45, H50, H63, H70, H90C and H100

*For Mini Excavators, Skid Steers and Backhoe Loaders*

---

## High Blow Rate

Very high blow rate means very high productivity for all hammers.

---

## Wide Carrier Versatility

Wide range of oil flow matches more Cat® and other machines and reduces likelihood of improper machine setting.

---

## Constant Blow Energy

Maximum and constant blow energy regardless of the oil flow adjustment (within the given min and max oil flow specifications).

---

## Full Length Side Plates

Powercell completely protected through full-length side plates. Front head is not exposed.

---

## Dependability

Service and parts available through the worldwide Cat Parts System.

## *Quality Construction*

*Caterpillar® design constructed for dependability and rugged job site performance.*

---

## Energy Efficient

Matching the mass and diameter of the piston to the mass and diameter of the tool helps ensure optimum energy transfer.

---

## Slip Fit Lower Tool Bushing

Slip fit field serviceable lower tool bushing with internal dust seal. Bushing includes grease retention grooves for better lubrication. Dust seal helps keep dirt out to provide longer life of the bushing and tool.

---

## Sound Suppression

Sound suppressed models available: H45 s, H50 s, H63 s, H70 s, H90C s and H100 s.

---

## Membrane Style Accumulator

Membrane accumulator versus gas accumulator meaning less maintenance and less downtime resulting in more productivity.

---

## High Pressure Accumulator

A high-pressure accumulator located on the back side of the hammer protects the carrier pumps from hydraulic pressure spikes.



# Hydraulic Hammers H115 s, H120C s, H130 s, H140D s, H160D s, and H180 s

*For Hydraulic Excavators*

---

## Sealed Housing

Powercell protected, fully enclosed in housing. Bottom of housing is closed and sealed while the covers prevent material intrusion on the top.

---

## Sound Suppression

All large hammer models are delivered in sound suppressed version. This results in greater operator comfort and environment protection.

---

## Dust Seal

A Dust Seal prevents foreign material from entering the housing. This reduces wear on the power cell and other major components.

---

## Hammer & Carrier Protection

The effective suspension system, including buffer and side pads, not only protects the hammer but also the carrier from recoil forces.

---

## Field Replaceable Lower Tool Bushing

Special care is given to the lower tool bushing. It can be replaced in the field and is rotatable for extended service life. The bushing has internal grooves for longer grease retention, and a seal to keep dirt outside and noise inside. This is a cost saver as the lower tool bushing and the tool are the items most exposed to wear.

---

## High Pressure Accumulator

High Pressure hydraulic accumulator is field serviceable and protects both the hammer circuit and carrier pump from hydraulic pressure spikes.

---

## Special Applications

Built-in lubrication port and air port make it easy to convert the hammer to automatic greasing and underwater use.

---

## Maximum Power

The simple and effective design of the powercell helps produce maximum power, a single piston and simple valving being used.

---

## Automatic Shut-Off (ASO)

Prevents blank firing of the piston. Reliability and durability are increased as high stress levels internal to the hammer are reduced. Available in D series.



# Hammer Models H45, H50, H63, H70, H90C and H100

- 1. Low Pressure Accumulator** – Assists in the power stroke of the piston.
- 2. Custom Sideplates** – Designed for Caterpillar® carrier geometry. Protects the powercell and front end.
- 3. High Pressure Accumulator** – Dampens pressure peaks thus protecting the carrier hydraulic system (not shown).
- 4. Distributor** – High oil volume for greater blow frequency.
- 5. Pressure Adjusting Valve (PAV)** – Assures that all blows are delivered at a constant blow energy.
- 6. Piston** – Long heavy piston delivers maximum impact energy and minimizes recoil forces to carrier.
- 7. Auto-Lube Connection** – Ensures proper tool greasing.
- 8. Slip Fit Thrust Ring** – Dissipates harmful shock loads in abusive applications.
- 9. Slip Fit Upper Tool Bushing** – Positive alignment for the tool.
- 10. Long Front End** – Ensures proper piston tool alignment.
- 11. Tool Retention Pin System** – Allows quick and easy removal of tool.
- 12. Side Plate Fastener** – Working forces carried through cap screws and front end.
- 13. Slip Fit Lower Tool Bushing (Field Replaceable)** – Grease retention grooves for extended lubrication and wear indication.
- 14. Dust Seal** – Dust Seal helps prevent foreign material from entering the lower bushing area. This reduces the wear on the lower bushing and tool.
- 15. Tool** – Heat treated for longer life. Ideally matched to piston for optimum transfer of stress waves.

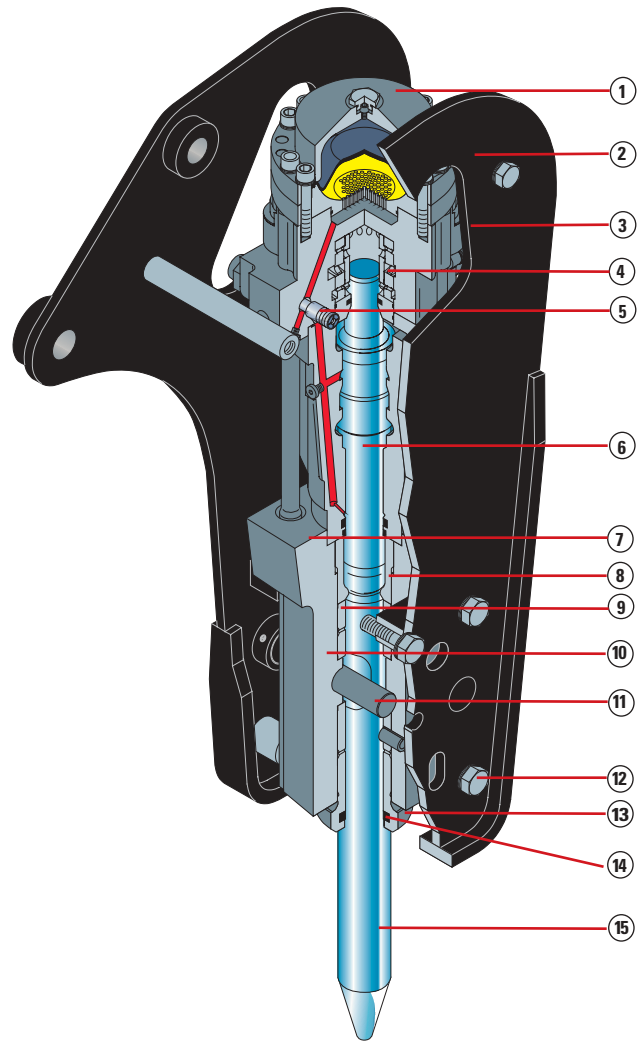

# Hammer Models H115 s, H120C s, H130 s, H140D s, H160D s, H180 s

- 1. & 7. Shock Absorbers** – Provide maximum shock and recoil protection for both hammer and carrier.
- 2. Accumulator** – Self contained diaphragm accumulator designed for long life.
- 3. Housing** – Symmetrical lean enclosed housing – no parts to break through external shock.
- 4. Hydraulic valves** – The Pressure Control Valve maintains maximum hydraulic pressure to ensure that the hammer delivers all blows at full power. A check valve isolates harmful pulsation spikes from the carrier hydraulic circuit.
- 5. Auto-Lube Connection** – Ensures proper tool greasing
- 6. Auto Shut Off (ASO)** – prevents blank firing and extends hammer life by reducing internal stress and heat. Currently available only with H140D s.
- 8. Seal carrier** – Contains special high performance seals to ensure leak-proof operation.
- 9. Hydraulic brake** – Dampens idle strokes and prevents steel to steel contact between piston and cylinder.
- 10. Piston** – Long piston transfers a long shock wave into the rock. Tool -piston diameters are matched for maximum energy transfer.
- 11. Tie-Rods** – Heat-torqued tie rods ensure maximum clamping force and minimum maintenance.
- 12. Cylinder** – Low recoil stress.
- 13. & 16. Wear Plates** – High abrasion resilient plastic wear plates between hammer and housing reduce noise and guide hammer assembly properly.
- 14. Upper tool bushing** – Guides the tool to optimize in-line piston to tool contact.
- 15. Tool retaining pins** – Allow quick and easy tool maintenance.
- 17. Rock Claw** – Special high abrasion resistant rock claw, enables quick positioning of boulders, gives maximum wear life.
- 18. Lower tool bushing** – Easily replaceable during normal maintenance. Circular retention grooves retain grease and lower friction between tool and bushing.
- 19. Dust Seal** – Dust Seal helps prevent foreign material from entering the housing. This reduces the wear on the lower bushing and tool.
- 20. Tool** – Specially heat-treated tools match piston diameter and mass, to deliver full blow energy.

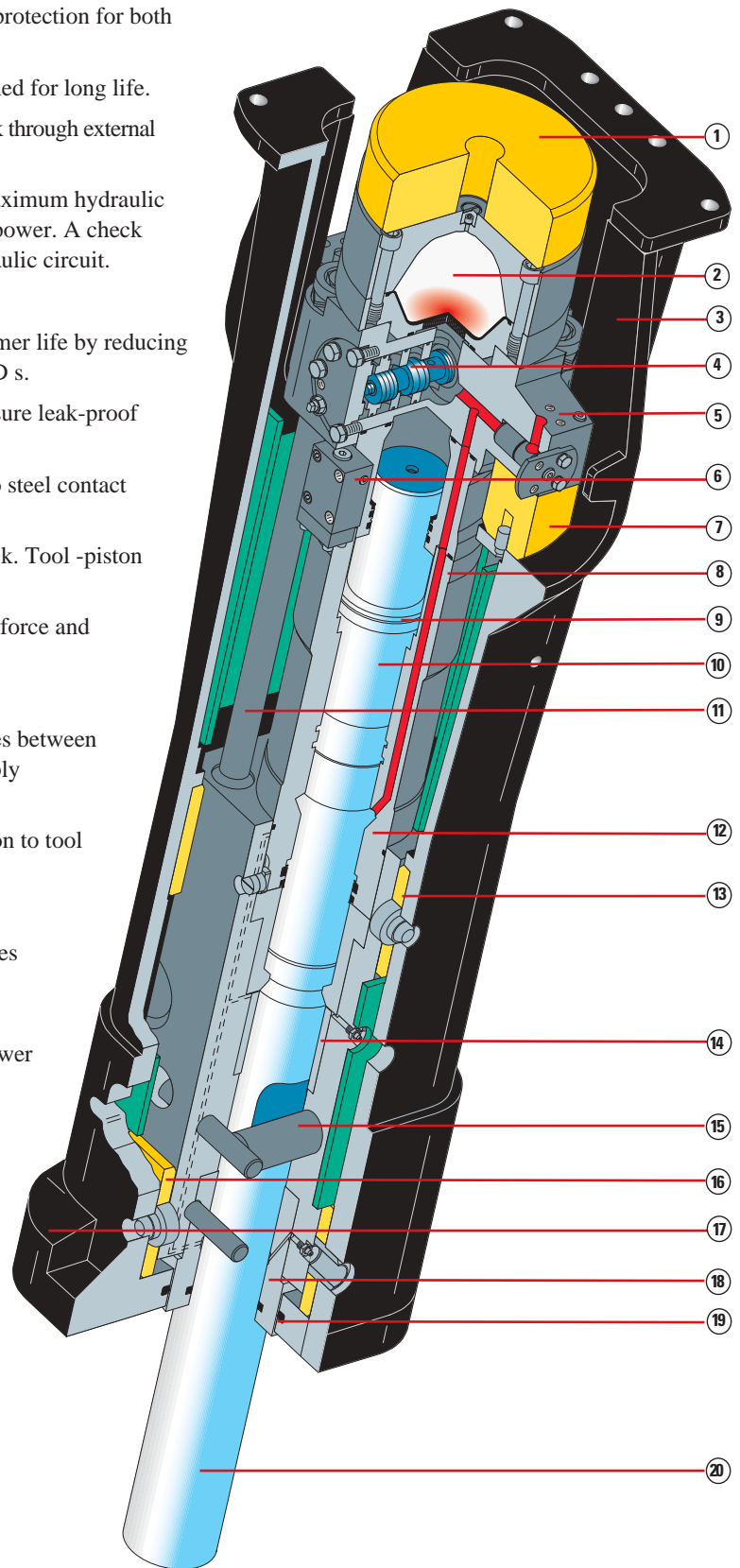

# Hammer Tools Applications Guide

## Standard Tools



### Chisel (C)

#### Applications

- Sedimentary and weak metamorphic rock into which tool penetrates
- Concrete
- Trenching\*
- Benching\*
- Tunneling\*

#### Select when:

- Working in non-abrasive but ductile rock
- Needing medium penetration rate into rock



### Moil (M)

#### Applications

- Sedimentary and weak metamorphic rock into which tool penetrates
- Concrete
- Trenching\*
- Tunneling\*

#### Select when:

- Working in soft, non-abrasive rock
- Needing greater protection against excessive retaining pin groove wear



### Blunt (B)

(for models H115 s to H180 s)

#### Applications

- Igneous and tough metamorphic rock into which tool doesn't penetrate
- Concrete
- Breaking boulders\*

#### Select when:

- Working in low or medium abrasive rock
- Tool wear rate is low

\* Applicable only when used on large hammers (minimum size H115 s)

## Special Tools

For models H45 to H70



### Spade (parallel or transverse) (S)

#### Applications

- Frozen or compact ground
- Asphalt

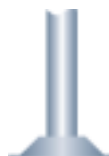

### Compacting Plate (CP)

#### Applications

- Ground compacting

For models H115 s to H180 s

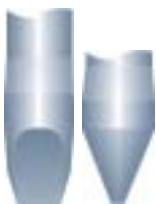

### Soft Rock Chisel (SR)

#### Select when:

- Very soft and easily breaking non-abrasive rock
- High penetration rate
- No excessive retaining pin groove wear



### Pyramidal Moil (P)

#### Select when:

- Working in soft, non-abrasive rock.
- Needing maximum penetration rate

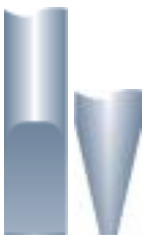

### Hard Rock Chisel (HR)

#### Select when:

- Working in hard and abrasive rock with cracks
- Needing low to medium penetration rate



### Super Blunt (SB)

#### Select when:

- Working in hard and abrasive rock-wear life 1.5 to 3 times longer than standard blunt in abrasive material.
- Breaking only boulders

# Hammer Tools Applications Guide

Symbols for tools:

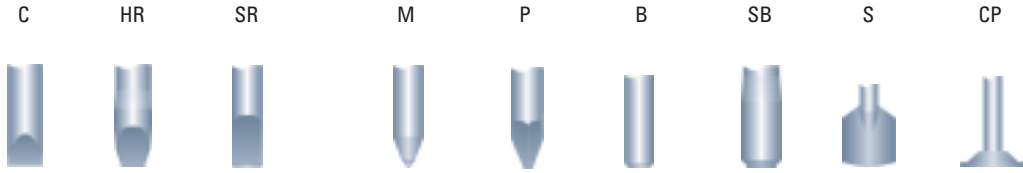

	H45	H50	H63	H70	H90C	H100	H115 s	H120C s	H130 s	H140D s	H160D s	H180 s
<b>1. Roadbuilding / construction</b>												
Breaking of road surface (concrete, asphalt)	S	S	S	S	C	C	C	C	SR,C	SR,C	SR,C	SR
Asphalt cutting to shape or area	S	S	S	S	C	C	C	C	SR,C	SR,C	SR,C	SR
Breaking uneven bedrock to lay a road						M,C	M,C	M,C	C,SR/HR	C,SR/HR	C,SR/HR	C,SR/HR
Primary Breaking to lay a road										C,SR/HR	C,SR/HR	C,SR/HR
Trench excavation for drainage				C	C	M,C						
Demolition of bridges						M,C	M,C	M,C	C,M,B	C,M,B	C,M,B	C,M,B
Heavily reinforced bridge pillars										B,SB	B,SB	B,SB
Compacting the ground	CP	CP	CP	CP								
Punching of holes (for traffic signs, lamp posts)					M	M						
Breaking of frozen ground		C,S	C,S	C,S	C,S	C,M	P,C	P,C	P,SR,C	P,SR,C	P,SR,C	P,SR,C
<b>2. Demolition / housing development</b>												
Demolition of concrete walls, roofs, floors	C,M	C,M	C,M	C,M	C,M	C,M,B	C,M,P	,M,P	C,SR,P	C,SR,P	C,SR,P	C,SR,P
Demolition of light, reinforced concrete foundation	C,M	C,M	C,M	C,M	C,M	C,M,B	P	P	SR,P			
Brick walls	C,M	C,M	C,M	C,M	C,M	C,M,B	C,M,B	C,M,B	C,SR/HR			
Trenches for mains / water supply / utilities					C,M	C,M	C,M	C,M	C,SR/HR			
Rock excavation for foundation					C,M	C,M	C,M	C,M	C,SR/HR	C,SR/HR	C,SR/HR	C,SR/HR
Mass excavation of rock for industrial buildings									C,SR/HR	C,SR/HR	C,SR/HR	C,SR/HR
Massive reinforced concrete foundations										SR,P	SR,P	SR,P
Breaking of frozen ground	C,M	C,M	C,M	C,M	C,M	C,M						
Breaking of hard ground (not rock)					C,M	C,M	C,M	C,M	C,SR	C,SR	C,SR	C,SR
Separating rebar from concrete (for recycling)				M,C	M,C	M,C	M,C	M,C	C,SR	C,SR	C,SR	C,SR
<b>3. Quarrying / open cast mining</b>												
Secondary breaking of blasted rock							B	B	B,SB	B,SB	B,SB	B,SB
Primary breaking of rock							C,M	C,M	C,SR/HR	C,SR/HR	C,SR/HR	,SR/HR
Breaking of oversizes on grizzly or feed chute					M	B	B	B	B,SB	B,SB		
Breaking of oversizes after blasting					M	B	B	B	B,SB	B,SB	B,SB	B,SB
Breaking oversizes on a crusher / feeder					M	B	B	B	B,SB	B,SB		
<b>4. Underground applications</b>												
Scaling in tunnel roofs and walls				C	C	C						
Trenching in tunnels								C,M	C,SR/HR	C,SR/HR	,SR/HR	C,SR/HR
<b>5. Metallurgical applications</b>												
Breaking of slag in casting ladles		C,M	C,M	C,M	C,M	C,M	C,M					
Breaking of slag in converter openings						C,M	C,M	C,M	C,M			
Breaking of refractory linings in furnaces	C,M	C,M	C,M	C,M								
Cleaning of castings					C,M	C,M	C,M					
Breaking of massive steel slag											B,SB,HR	B,SB,HR
Breaking of aluminium electrolyse slag											B,HR	B,HR
<b>6. Other applications</b>												
Rock breaking where blasting is restricted										C,SR/HR	C,SR/HR	C,SR/HR
Demolition under water							P	P	P			
Rock breaking under water										C,SR/HR	C,SR/HR	C,SR/HR

# Hammer-Carrier Matching Guide

	H45	H50	H63	H70	H90C	H100	H115 s	H120C s	H130 s	H140D s	H160D s	H180 s
<b>Mini Excavators</b>												
301.5/301.5CR/301.6/301.8	•											
302.5	•	•										
303CR/303SR		•	•#									
303.5		•	•									
304CR/304.5			•									
305CR/305SR			•									
<b>Skid Steer Loaders *</b>												
216B/226B/232B	•**	•	•									
236B/242B/246B/248B			•									
252B/262B/268B			•									
<b>Multi Terrain Loaders</b>												
247B		•	•									
257B/267B/277B/287B			•									
<b>Backhoe Loaders</b>												
416D			•	•	•							
420D/424D/428D				•	•							
430D/432D				•								
438D/442D				•	•							
446D					•	•						
<b>Hydraulic Excavators</b>												
307C/307C SB				•	•							
308C CR/308C SR					•							
311C U					•	•						
312C					•	•	•					
313C CR/313C SR						•	•					
314C CR						•	•					
315C						•	•	•				
317B L							•	•				
318C							•	•				
319C							•	•				
M313C						•	•					
M315C						•	•	•				
M316C						•	•	•				
M318C							•	•	•			
M322C							•	•	•			
320C							•	•	•			
321C							•	•	•			
322C								•	•	•		
325C								•	•	•		
330C									•	•	•	
345B II											•	•
365B II												•

Caterpillar recommends the use of a suitable shield/guard system to assure the operator has adequate protection form.

# Installation of add-on optional, counterweight to machine is required.

\* SSL with BH30 or BH30w match hammers to SSL models as per above.

\*\* Special configuration - only applicable when machine is fitted with backhoe attachment BH27.



# Hammer and Tool Dimensions

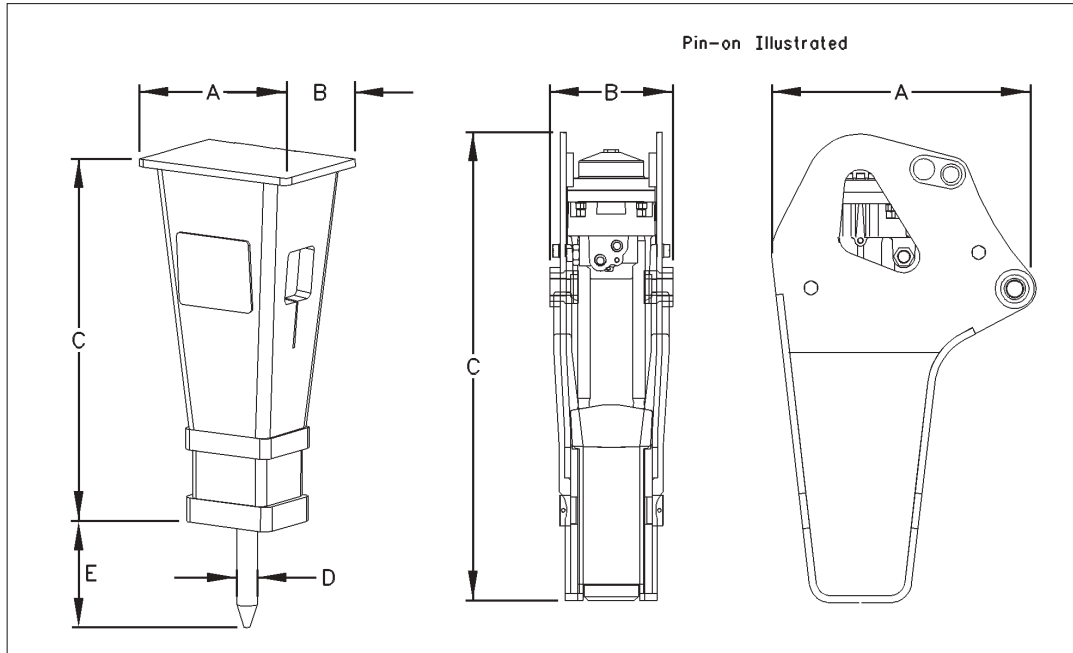

Type	A Frontal Width of Hammer		B Lateral width of Hammer		C Hammer Housing / Side Plate Length		D Hammer Tool Diameter		E Hammer Tool Length*	
	in.	mm	in.	mm	in.	mm	in.	mm	in.	mm
H45 Flat Top	13.4	340	11	280	30.5	775	1.8	45	10.3	262
H45 s Flat Top	17.3	440	11	280	30.5	775	1.8	45	9.8	249
H50 Flat Top	13.4	340	11	280	36.4	925	2.0	50	10.3	262
H50 s Flat Top	17.3	440	12.4	316	36.1	918	2.0	50	10.3	262
H63 Flat Top	18.5	470	15	380	40.3	1025	2.5	63	14.3	364
H63 s Flat Top	17.3	440	15	380	40.3	1025	2.5	63	14.3	364
H70 Flat Top	18.5	470	15	380	44.6	1134	2.8	70	15.8	402
H70 s Flat Top	20.5	520	15.7	400	45.3	1150	2.8	70	15.3	390
H70 Pin-on	27.1	690	13.7	348	48.3	1228	2.8	70	14.0	355
H90C Flat Top	20.1	510	15	380	50.6	1286	3.3	84	16.4	417
H90C s Flat Top	20.5	520	15.7	400	50.9	1294	3.3	84	16.4	417
H90C Pin-on	29.4	749	13.7	348	52.1	1325	3.3	84	16.4	417
H100 Flat Top	23.0	585	21.3	540	54.9	1397	3.7	95	18.1	459
H100 s Flat Top	23.0	585	21.3	540	54.8	1394	3.7	95	18.1	459
H100 Pin-on	24.9	633	16.7	426	60.0	1526	3.7	95	18.1	459
H115 s Flat Top	23.0	585	21.3	540	63.9	1625	4.2	106	15.4	390
H120C s Flat Top	23.0	585	21.3	540	70.1	1783	4.5	115	14.1	357
H130 s Flat Top	23.0	585	21.3	540	74.1	1885	5.1	130	15.6	397
H140D s Flat Top	23.0	585	21.3	540	85.3	2167	5.5	140	18.6	472
H160D s Flat Top	28.7	730	28.7	730	91.4	2326	6.3	160	24.8	632
H180 s Flat Top	28.7	730	28.7	730	97.4	2478	6.7	170	20.9	532

\* Typical Hammer tool length only. Actual length may vary according to tool type. Please see PSK GET for further details if required.

# Hammer Specifications

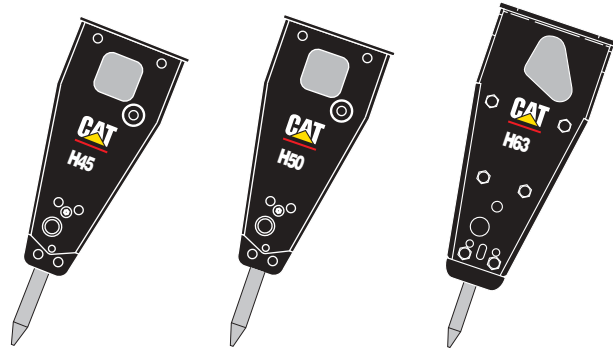

Hammer Model		H45	H50	H63
Recommended Carrier Weight	lbs	2,860-7,040	5,500-9,900	6,600-14,300
	(kg)	(1,300-3,200)	(2,500-4,500)	(3,000-6,500)
*Working Weight	lbs (kg)	286 (130)	440 (200)	660 (300)
Impact Frequency	(bpm)	830-2,500	460-2,000	420-2,000
Energy Class	ft lbs (J)	200 (271)	400 (542)	500 (678)
Acceptable Oil Flow	gal/min	5.2-13	5.2-18	8-26
	(L/min)	(20-50)	(20-70)	(30-100)
**Operating Pressure	psi	2,030	1,740	2,030
	(kPa)	(14,000)	(12,000)	(14,000)

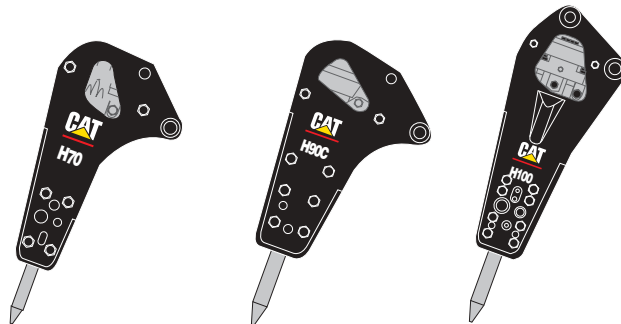

Hammer Model		H70	H90C	H100
Recommended Carrier Weight	lbs	11,000-17,600	13,200-26,400	17,600-30,800
	(kg)	(5,000-8,000)	(6,000-12,000)	(8,000-14,000)
*Working Weight	lbs (kg)	814 (370) ***	1,206 (547) ***	1,588 (720) ***
Impact Frequency	(bpm)	600-1,850	500-1,450	430-1,300
Energy Class	ft lbs (J)	750 (1,017)	1,000 (1,356)	1,500 (2,034)
Acceptable Oil Flow	gal/min	13-40	16-40	16-32
	(L/min)	(50-150)	(60-150)	(60-120)
**Operating Pressure	psi	2,030	1,958	2,103
	(kPa)	(14,000)	(13,500)	(14,500)

\* Working weight includes hammer, standard tool and average mounting bracket.

\*\* Approximate operating pressure at maximum flow and back pressure.

\*\*\* Pin-on version. Sound suppressed versions have slightly higher working weight.

# Hammer Specifications

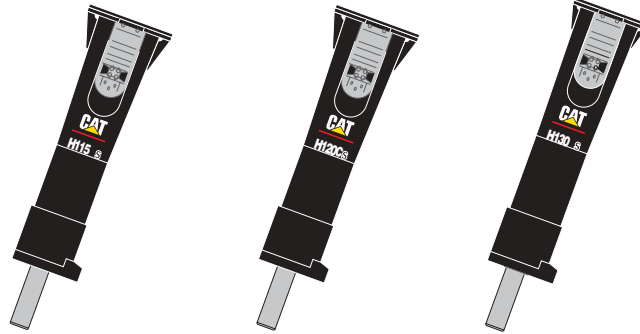

Hammer Model		H115 s	H120C s	H130 s
Recommended Carrier Weight	lbs	26,400-44,000	37,400-57,200	41,800-70,400
	(kg)	(12,000-20,000)	(17,000-26,000)	(19,000-32,000)
*Working Weight	lbs (kg)	2,200 (1,000)	2,860 (1,300)	3,740 (1,700)
Impact Frequency	(bpm)	370-800	350-620	320-600
Energy Class	ft lbs (J)	2,500 (3,390)	3,000 (4,067)	3,500 (4,745)
Acceptable Oil Flow	gal/min	18-34	26-45	32-58
	(L/min)	(70-130)	(100-170)	(120-220)
**Operating Pressure	psi	2,030	2,030	2,030
	(kPa)	(14,000)	(14,000)	(14,000)

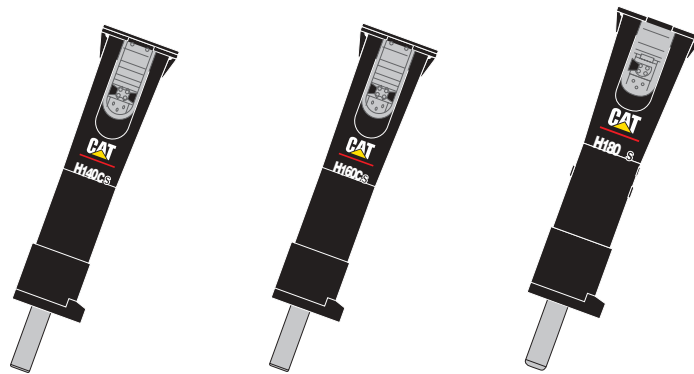

Hammer Model		H140D s	H160D s	H180 s
Recommended Carrier Weight	lbs	55,000-88,000	70,400-121,000	88,000-176,000
	(kg)	(25,000-40,000)	(32,000-55,000)	(40,000-80,000)
*Working Weight	lbs (kg)	5,182 (2,355)	6,946 (3,157)	8,360 (3,800)
Impact Frequency	(bpm)	350-600	380-560	370-520
Energy Class	ft lbs (J)	5,000 (6,779)	7,500 (10,169)	11,000 (14,913)
Acceptable Oil Flow	gal/min	42-60	58-82	57-78
	(L/min)	(160-230)	(220-310)	(220-300)
**Operating Pressure	psi	2,321	2,321	2,321
	(kPa)	(16,000)	(16,000)	(16,000)

\* Working weight includes hammer, standard tool and average mounting bracket.

\*\* Approximate operating pressure at maximum flow and back pressure.

# Hydraulic Hammers

[www.CAT.com](http://www.CAT.com)

© 2004 Caterpillar  
Printed in U.S.A.

Materials and specifications are subject to change without notice.  
Featured machines in photos may include additional equipment.  
See your Caterpillar dealer for available options.

YEKN0343 (06-04)

